

Product advantages mobile crane

LTM 1400-7.1

Max. load capacity: 400 t
Max. height under hook: 130 m
Max. radius: 100 m



LIEBHERR

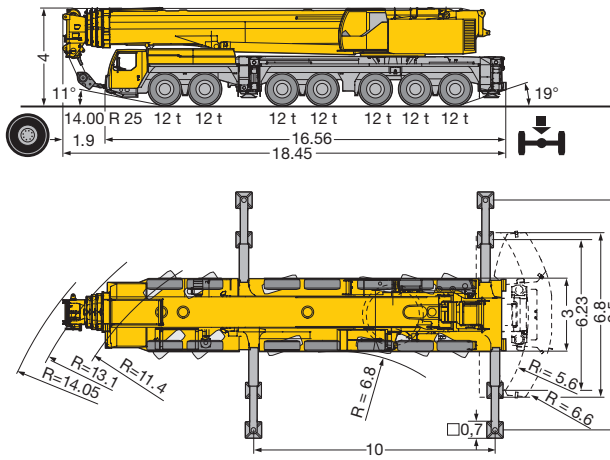

Compact, maneuverable and safe

- Overall length 18.45 m, carrier 16.56 m long
- Overhang angles, front up to 11°, rear up to 19°
- Smallest turning radius by active rear-axle steering, 13.6 m over carrier
- Drive 14 x 6, axles 1, 3 and 5 are driven
- Drive 14 x 8, axles 1, 3, 5 and 6 are driven; 6th axle activatable for off-road displacement
- Driving axles with differential locks for lateral blocking to increase the off-road quality
- Total weight 84 t, uniform axle load distribution (12 t) due to hydropneumatic suspension "Niveumatik"
- Telescopic boom guying system can technically be carried along by the crane
- For safe displacement, in addition to the service and parking brakes, retarder in the TC-TRONIC gear and exhaust retarder with Liebherr-additional braking system by valve control (ZBS) as standard features; TELMA eddy-current brake on the 4th axle (optional)



Modern drive concept

- Powerful, 8-cylinder Liebherr turbo-charged Diesel engine D9508 A7 of 450 kW/612 hp, exhaust emissions acc. to 97/68/EG stage 3 and EPA/CARB Tier 3, robust and reliable, modern electronic controlled engine management
- Automated gear system ZF-TC-TRONIC with converter and retarder; 12 forward and 2 reversed speeds, automated control
- Reduced fuel consumption due to a great number of speeds, sensitive maneuvering due to converter
- 1-step, robust transfer case with transfer differential
- Weight-optimized, robust axles of minor maintenance, good track keeping due to special drag-links and precise lateral guidance; maintenance-free steering nuckles mounted on steel-armoured rubber
- Maintenance-free cardan shaft; simple and quick fitting due to 70° diagonal toothing

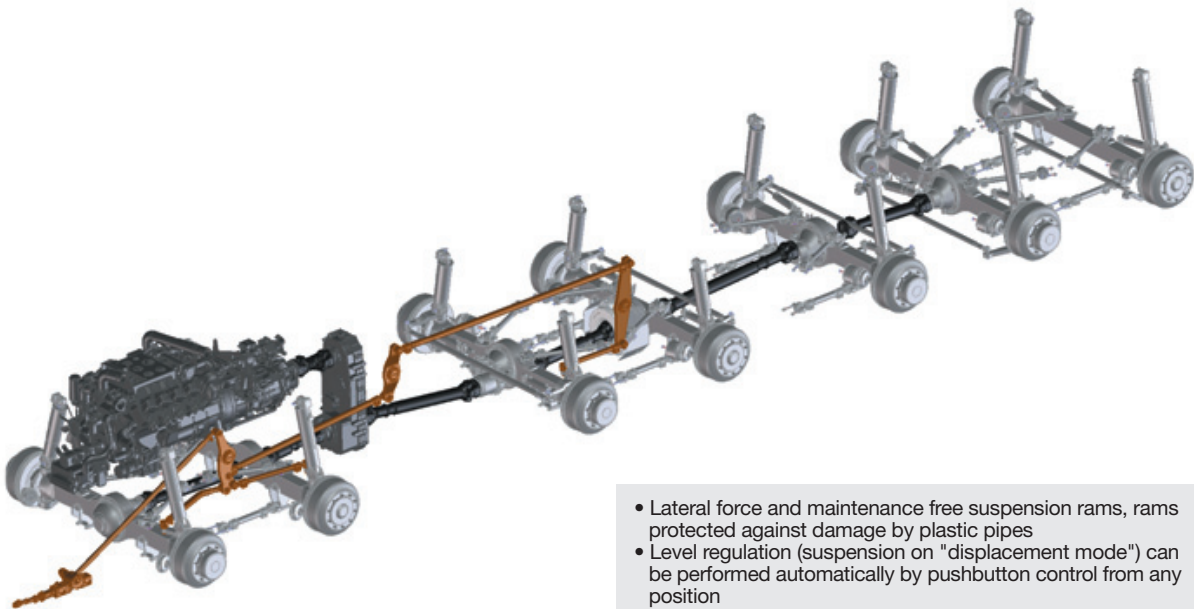

- Lateral force and maintenance free suspension rams, rams protected against damage by plastic pipes
- Level regulation (suspension on "displacement mode") can be performed automatically by pushbutton control from any position
- Stable cornering ability of the crane due to cross-linkage of the hydropneumatic suspension
- Max. displacement speed 80 km/h, max. gradability 39 %

Variable steering concept with "active rear-axle steering"

Axles 4 – 7 provided for "active rear-axle steering", 5 steering methods are preselectable by fixed programs (P)

P1 Road displacement steering

Axles 1 – 3 are steered mechanically by means of the steering wheel with hydraulic assistance. Axles 4 and 5 are steered "actively", speed-dependent up to 30 km/h in relation to the degree of lock of the front axle, and set and blocked to straight displacement at over 30 km/h. Axles 6 and 7 are steered "actively", speed-dependent up to 60 km/h, in relation to the degree of lock of the front axles, and set electrohydraulically to straight displacement up to 60 km/h. The modification of the steering angle in dependence of the speed guarantees a precise and stable displacement quality and reduces the abrasion of the pneumatics.

P2 All-wheel steering

Axles 4 – 7 are locked in conformance with the steering angle of the 1st axle by means of the steering wheel to realize the smallest turning radii.

P3 Crab steering

Axles 4 – 7 are locked in the identical sense of axles 1 – 3 by means of the steering wheel. The raising of the axles is not necessary for crab steering as all axles are steered.

P4 Steering without swerving out

Axles 4 – 7 are locked in relation to the steering angle of the 1st axle to prevent any swerving out of the rear of the carrier.

P5 Manual crab steering

Axles 1 – 3 are steered by means of the steering wheel, axles 4 – 7 are steered independently from the steering lock of axles 1 – 3 by pushbuttons.

- In case of a failure of the active rear-axle steering, it is rendered ineffective and the rear axles are set to straight travel by the centering rams
- Two independent hydraulic circuits with wheel and engine driven hydraulic pump, thus maximum safety standard
- Two independent steering processors (by existing E/A modules) and divergent sensory system
- The entire know-how for the "active rear-axle steering" by Liebherr

P1

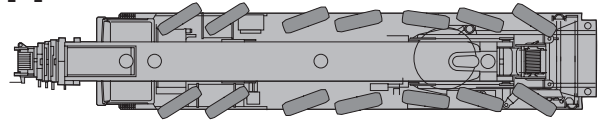

P2

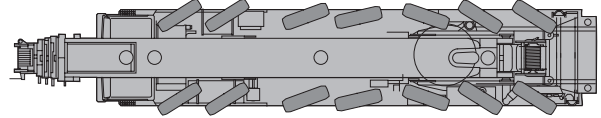

P3

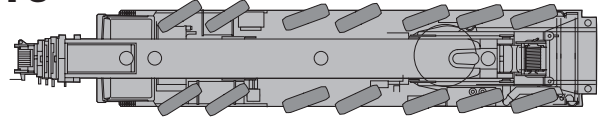

P4

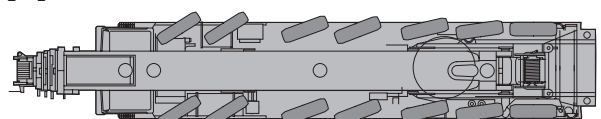

P5

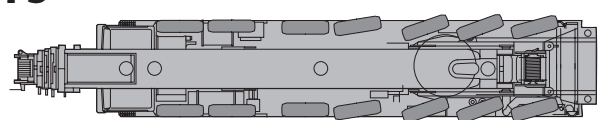

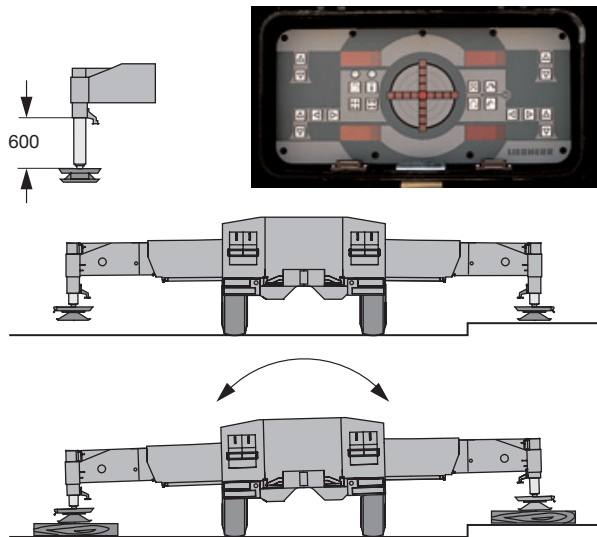

Setting crane on outriggers - quick, convenient and safe

- Supporting basis: 10 m x 9.5 m or 10 m x 6.23 m
- Fixed supporting pads with lateral compensation
- Supporting rams with 600 mm travel
- Level control of the outriggers, all-automatic levelling of the crane during the supporting procedure by "push-button control"
- 2 x 9° lateral inclination of the carrier, thus simple underlay of the supporting pads
- Inclinator (electronic inclination indication), two displays on the carrier and a display on the LICCON monitor in the crane cab
- 2 supporting force indicators on the control panels on the carrier and on the LICCON display screen to indicate the supporting force on the supporting rams
- 4 projectors for the illumination of the supporting zone
- Axle locking (blocking of the suspension for the displacement with equipment) controllable from the driver's cab
- Operation of the outrigger system in accordance with the rules for the prevention of accidents



Comfortable driver's cab of outstanding functionality

- Modern driver's cab of outstanding functionality and convincing design. Corrosion resistant sheet steel version, cataphoretic dip-primed, front section mounted on shock absorbers, rear damped hydraulically, internal sound and heat absorbing panelling
- Safety glass all-round, greenish tinted front and side windows for heat insulation, electric window lifters
- 3 automatic windscreen washers/wipers with intermittent control
- Heated and electrically adjustable outer rear mirrors
- Air-cushioned driver's and co-driver's seat with headrests, driver's seat with pneumatic lumbar support
- Safety belts for driver's and co-driver's seat
- Height and inclination adjustable steering wheel
- Standardized, digital operating and control instruments arranged ergonomically for safe and convenient handling, arranged operator-friendly in a half-round shape
- Digital display and keyboard units interconnected with the functional blocks by data bus technology
- Additional heater with engine preheating



Comfortable crane cab of outstanding functionality

- Crane cab in corrosion-resistant, galvanized sheet steel version, powder-coated, with sound and heat insulating internal paneling, interior of modern design, tinted window panes all-round, front knockout window with large windscreen wiper and wash/wash device, skylight of bullet-proof glass with large parallel windscreen wiper and wash/wash device, roller blinds on front window and skylight, space-saving sliding door
- Greenish tinted front and side windows for heat absorption
- Pneumatic operated lateral foot board for safe access to and from the carrier
- Crane cab tiltable to the rear by 20° to improve the sight
- 1 working projector 70 Watt, at the cabin front



- Spring-mounted and hydraulically cushioned crane operator's seat with pneumatic lumbar support and headrest
- Operator-friendly armrest-integrated controls, vertically and horizontally adjustable master switch consoles and armrests, ergonomically adjustable operating consoles
- Ergonomical control levers with integrated winch and slewing indicators
- Modern instrument support with integrated LICCON monitor, display of all essential operating data on the LICCON display screen
- Additional heater with engine preheating



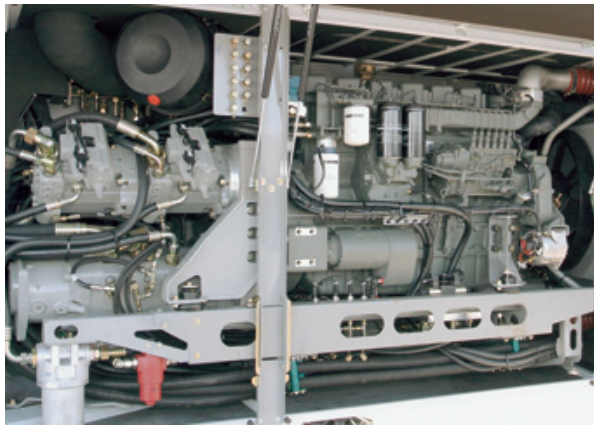

Crane drive with field-proven components

- Crane engine: 6-cylinder Liebherr turbo-charged Diesel engine type D936L A6 of 240 kW/326 h.p, exhaust gas emissions in accordance with the directives 97/68/EG stage 3 and EPA/CARB Tier 3, robust and reliable, electronic engine management, optimized fuel consumption, exhaust gas system of special steel
- Hydraulic system with 5 variable axial piston pumps with servo-control and capacity regulation, auxiliary pumps for central feeding and ventilator drive, electric driven oil cooler
- Standard high-efficiency noise absorption of the diesel-hydraulic crane drive

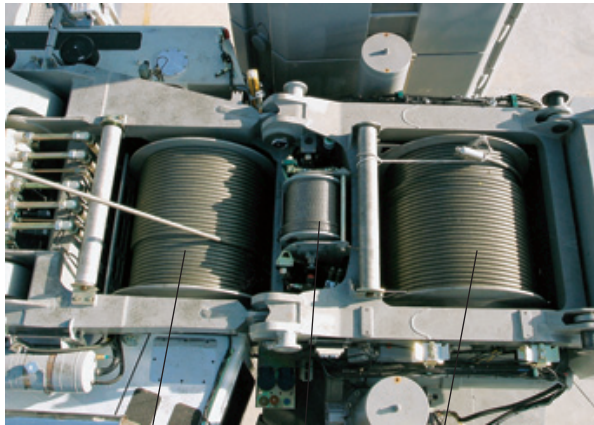

Winch 1 **Auxiliary winch** **Winch 2**
Winch 3

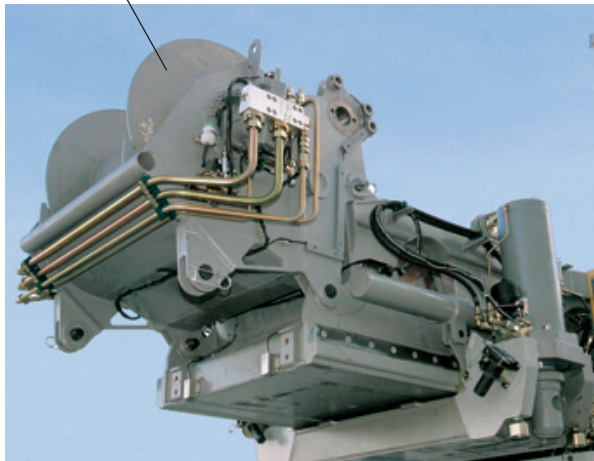

Winch technology by Liebherr

- Self-manufactured Liebherr winches (1, 2 and 3) with special grooving, with incorporated planetary gears and spring-mounted multi-disk brakes as static brakes

Winch 1

main hoist gear

Winch 2

auxiliary hoist gear, required for 2-hook operation with luffing lattice jib

Winch 3

for variation of the luffing lattice jib

Auxiliary winch

for reeving of the hook block and for the erection of the lattice luffing jib

- Drive of the hoist gear within a "closed oil circuit", i.e. during lowering of the load, the oil motor is propping itself up on the variable displacement pump due to the closed oil circuit (hydraulic shaft). The potential energy is not converted into heat, but can be re-employed for an additional movement. Besides a saving in fuel, the hydraulic oil is less thermally exposed than in an "open oil circuit"
- Axial-piston variable displacement motor of own manufacture, specially laid out for crane operation, exposed to tough fatigue test and field-proven
- Display of the rotary motion of the winch on the LICCON display screen
- Non-rotating hoist rope, standard rotation absorber
- Video control of the winches (standard in conjunction with the jib variation winch)

Counterweight assembly - just a matter of minutes

- 140 t total counterweight, 100 t basic counterweight, 40 t additional counterweight
- Hydraulic ballasting device on the counterweight frame
- "60-t-package" of just 3 m transport width, mountable by one lift
- Hoist gear 2 fitted to the counterweight frame
- Jib variation winch (winch 3) to be pinned on the counterweight frame
- The counterweight radius can be reduced from 6.6 m to 5.6 m by the displacement of the entire counterweight
- Reeving winch (auxiliary winch) on the counterweight frame as standard equipment

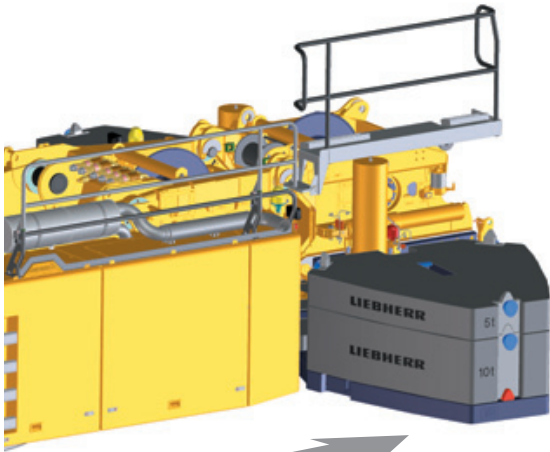

Partial counterweight, radius 5.6 m

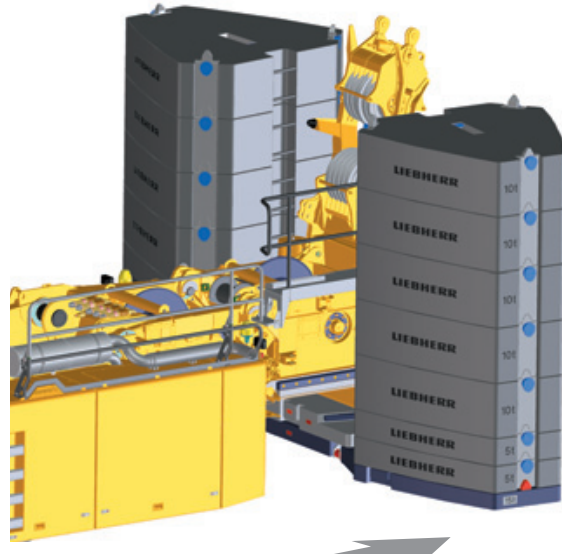

140 t total counterweight, radius 6.6 m



60 t-package with winch 3



Luffing jib mode, counterweight radius 5.6 m or 6.6 m

Outstanding boom technology

- 5-section, 60 m long telescopic boom in light-gauge design, weight-optimized by FEM processing
- Material stability with high safety factors by the application of ultra-high grain refined steels, boom bottom shell of S 1100 QL (1100 N/mm²)
- Optimated, oviform boom profile with continuous curvature in the bottom shell and upper offset joint, high stability against deflection for maximum load capacities
- Outstanding functionality of the boom system due to the automated, electronically controlled telescoping system "Telematik"
- Patented internal locking system of the telescopes – reliable and maintenance-free
- Optimal utilization of the telescopic boom due to a multitude of telescoping variants
- All telescopes are also telescopable under partial load
- Y-guying system for the telescopic boom for a distinctive increase of the load capacity
- The telescopic boom is always kept straight in its geometry, unaffected by lateral sun radiation or side wind. For that purpose, the stay ropes of the Y-guying system are wound onto two accumulator blocks on the Y-frames by two rope winches. Grips, pressed onto the stay ropes, define the rope lengths in relation to the telescopic boom lengths; limit switches control the positioning of the pressed-on grips; the stay ropes are locked to the pressed-on grips by means of tensioning rams in the Y-frames.
- Self-assembly of the Y-frames; carrier width/height with fitted and laterally hinged Y-guying system: 3.03 m/4.07 m

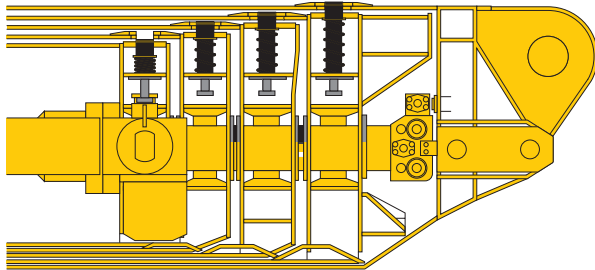

Multi variable boom configuration system

- Telescopic boom T, 15.4 m – 60 m
- Telescopic boom guying system TY, 5.25 m wide "spacer" for TYSF and TYSN mode
- Fixed lattice jib TF (TYSF), 7 m - 56 m, mountable at 0°, 20° or 40° on the 15.4 m – 60 m long telescopic boom
- Lattice luffing jib TN (TYSN), 14 m – 84 m, mountable on the 15.4 m – 56.4 m long telescopic boom
- Continuous load capacity interpolation during luffing of the boom configuration TN (TYSN) between 82° and 68° telescopic boom inclination
- Intermediate sections TF and TN equipment are identical, intermediate sections can be slid into one another for transportation
- Jib A-frames with T-adapter and N-base section form a complete mounting/transport unit and can be fitted with just 4 pins
- Easy-to-rig stay rods which remain on the intermediate sections during transportation
- Auxiliary winch on the counterweight frame for easy reeving of the hoist and luffing ropes
- Rigging of the jib can be performed in suspended condition on restricted sites
- Winch 2 for 2-hook operation on the lattice jib
- Winch 3 for jib variation. The variation winch forms one unit with the variation block. The variation rope remains reeved during transportation.

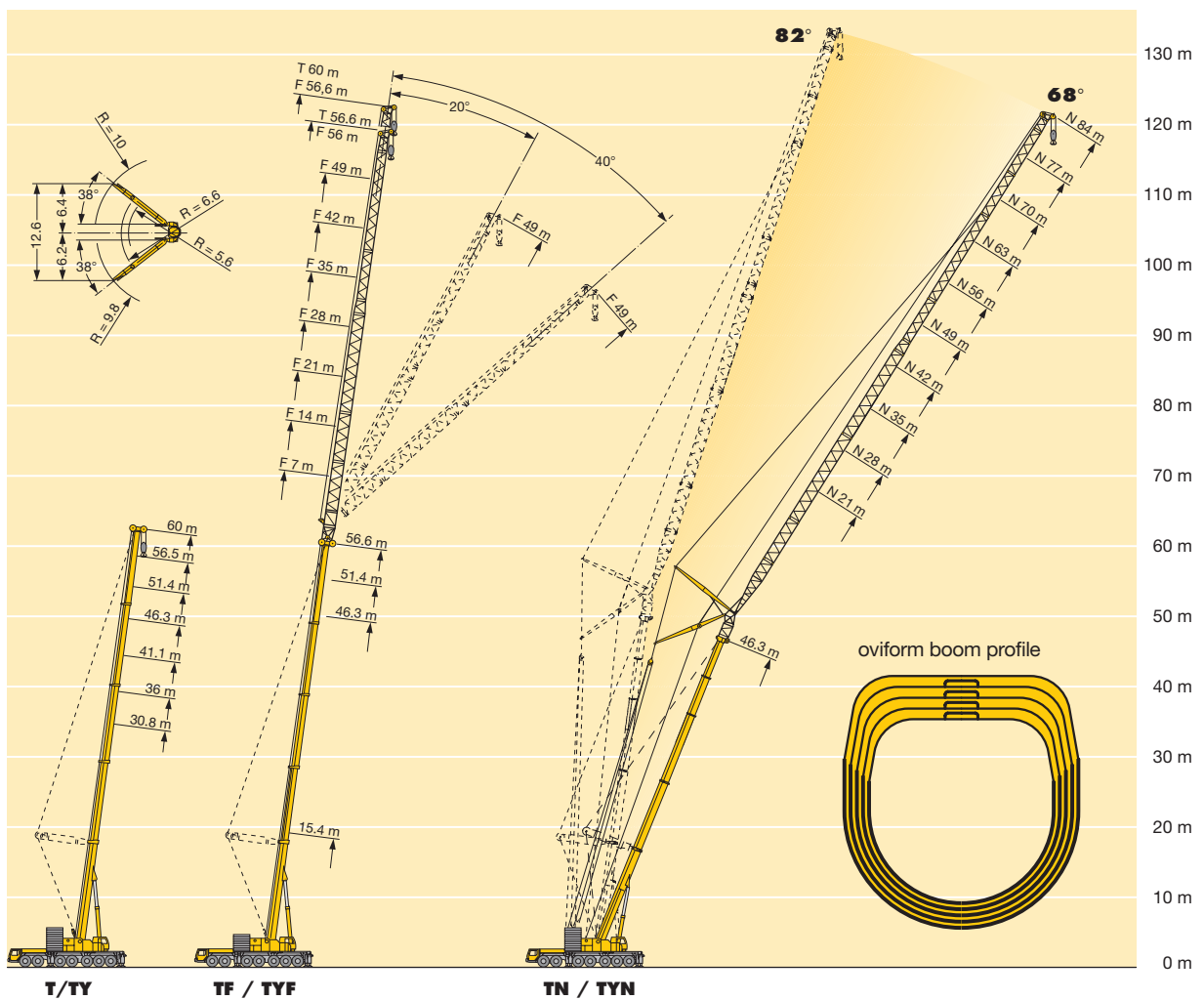

Components are interconnected by CAN bus transmission technology to the individual functional blocks instead of the conventional electric control system. This increases the functional reliability due to essentially

... specially designed CAN bus systems (LSB), especially for the control of the transmission of a mobile crane. The all-electronic drive system consumes less power and improves the performance of the crane as well as the reliability of the transmission system and the boom control system connected by 4 Liebherr-system

... blocks is realized by E/A modules, which are controlled by means of the CAN bus. The control intelligence is integrated into the CAN bus system, which provides facilities, quick error localization, and a high level of test of the keyboard and display of the control units of engine and transmission. Liebherr additional brake system, Liebherr suspension and outrigger control system. This technology distinctively increases the reliability of the mobile crane

- 10 LICCON monitor in crane cab
- 11 LICCON monitor in crane cab
- 12 Length sensor and cable drum/gripper/telescopic boom
- 13 Inductive sensor
- 14 Angle sensor on base section
- 15 Wind sensor
- 16 Cable drum for items 16, 17, 18 and 19
- 17 Hoist limit switch
- 18 Angle sensor
- 19 Input/output module for electronic engine/superstructure, ventilator
- 20 Control injection pump Liebherr D
- 21 Joystick selector
- 22 Pressure sensor for output manifold (indicator) and supporting pressure
- 23 Angle sensor active rear-axle steering
- 24 Steering block active rear-axle steering
- 25 Pedal telescoping
- 26 Winch rotation sensor
- 27 Inductive sensor Y-guying system

- 1 Input/output module for electronic control of the suspension, Liebherr Diesel engine, automatic transmission, control functions, pneumatic control for brake function
- 1a Instruments-keyboard unit in driver's cab
- 2 Input/output module for differential locks, display functions
- 2a Instruments-display unit in driver's cab
- 3 Input/output module for outriggers - right
- 3a Control unit for outriggers - right
- 4 Input/output module for outriggers - left
- 4a Control unit for outriggers - left
- 5 Input/output module for engine brake, tempomat, tempomat, electronic control Diesel engine (steering column switch right) and automatic transmission
- 6 Control ZF-TC-TRONIC automatic transmission

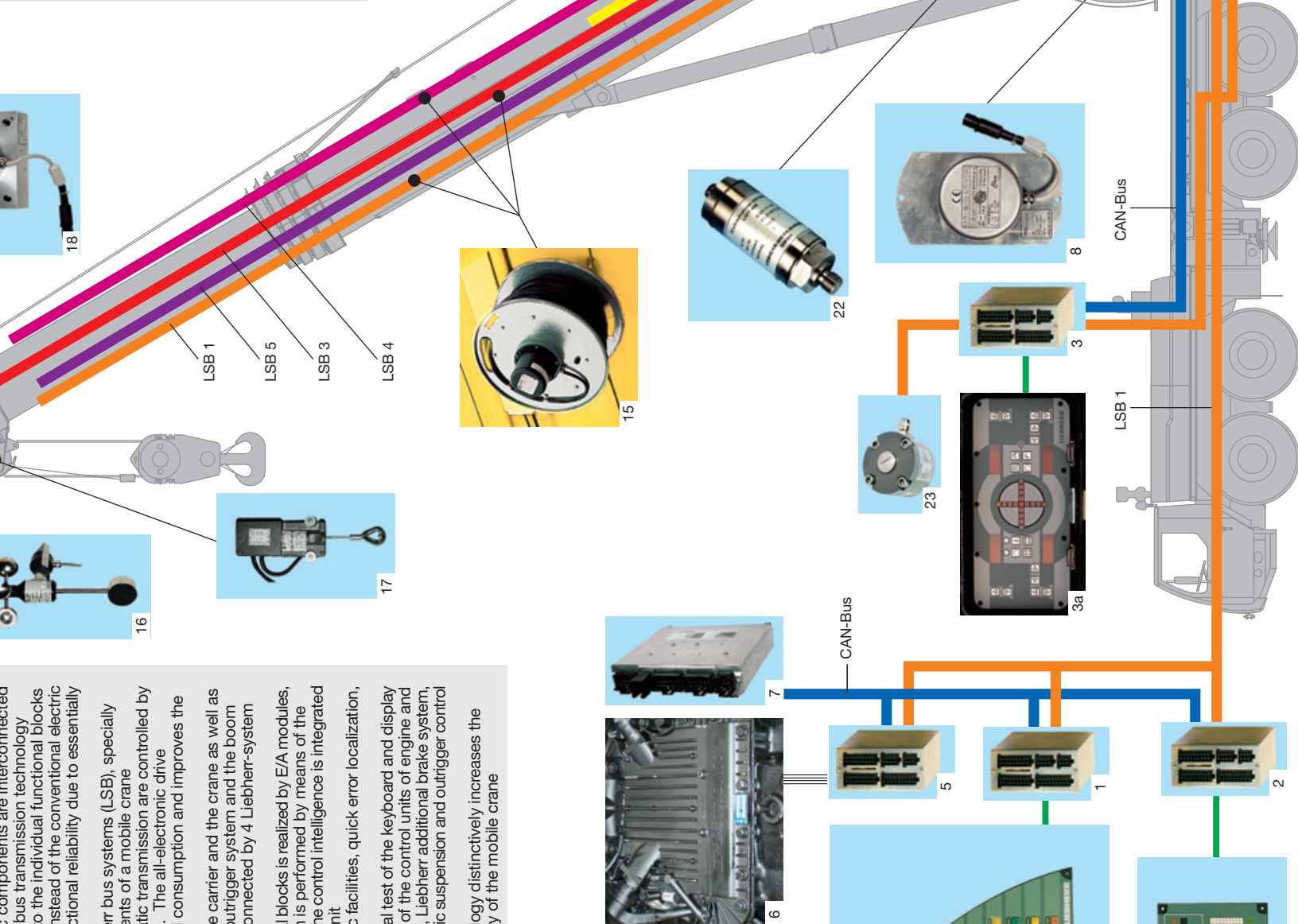
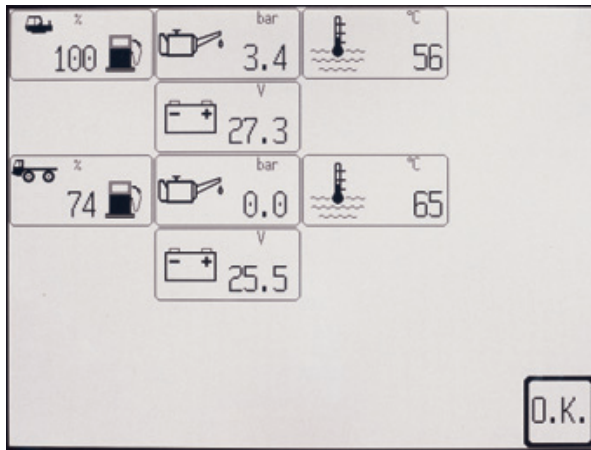

Diagram illustrating the CAN bus system architecture for a mobile crane, showing the connection between the main CAN bus and various Local Sub-Buses (LSB) and components.

LICCON configuration and operating program

- Serial application programs: Safe load indicator (LMB), configuration program with configuration picture, operating program with operating picture, telescoping program with telescoping picture, supporting pressure indication, control parameter program, test system; optional extras: Work area limitation and the LICCON work planner
- Setting of the configuration by convenient interactive functions
- Safe and conscious acknowledgement of the adjusted configuration
- Representation of all essential data by graphic symbols on the operating picture
- With integrated wind speed measuring system
- Reliable cut-off device when exceeding the admissible load moments
- Load capacity values for any boom intermediate length
- Winch display for precise lifting/lowering of the load



LICCON-assisted telescoping system

- Telescoping by single-stage hydraulic ram with hydraulic driving tenons (patented internal locking system)
- Telescoping procedure controllable by convenient operator guide on the monitor, the interlocking positions are precisely approached
- Telescopable loads are displayed on the LICCON operating picture
- Rapid-cycle telescoping system with "automatic mode", i.e. all-automatic telescoping to the desired boom length
- Very compact and light-weight telescoping system, thus load capacity increases especially with long booms and at large radii
- Automatic cushioning of the telescopes in end positions during telescoping and retracting to preserve the structural members

		CODE>0250<B146 2000.1(3)						
		46,3	46,3	46,3	51,4	51,4	56,6	60,2
9,0								
10,0								
12,0								
14,0	79,0	78,0	74,0	73,0	71,0	63,0	58,0	
15,0	72,0	71,0	68,0	67,0	65,0	58,0	54,0	
18,0	66,0	65,0	62,0	61,0	60,0	54,0	50,0	
20,0	60,0	60,0	57,0	56,0	55,0	50,0	47,0	
22,0	54,0	55,0	52,0	50,0	51,0	46,5	44,0	
24,0	48,5	49,5	49,0	45,5	47,5	43,5	41,0	
26,0	44,0	44,5	45,0	41,5	44,5	40,5	38,5	
* n *	7 *	7 *	7 *	6 *	6 *	6 *	5 *	
23(24)	<<							
1	46 +	46 +	0 +	92 +	46 +	92 +	100 +	
2	92 +	46 +	92 +	92 +	92 +	92 +	100 +	
3	92 +	92 +	92 +	92 +	92 +	92 +	100 +	
4	46 +	92 +	92 +	46 +	92 +	92 +	100 +	

Additional data at the bottom: TY --, 140.0 t, 10.0 x 9.5 m, 0 -> 6.5, 22 x, O.K.

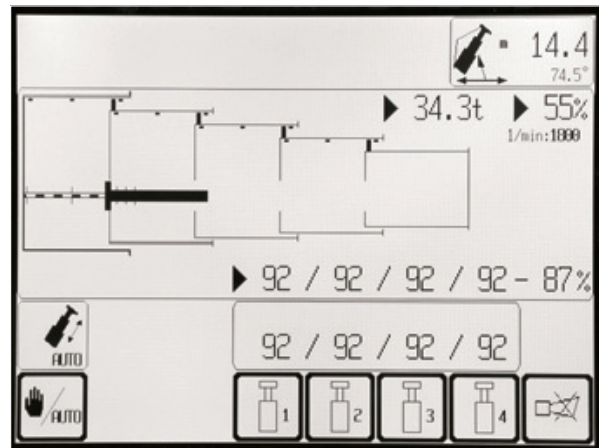
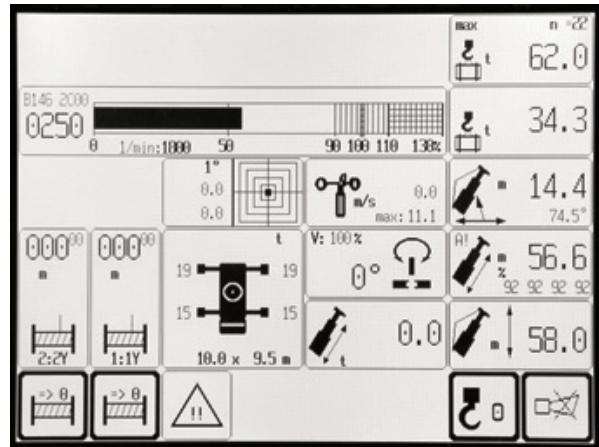

The LICCON test system

- The test system assists the servicing personnel in quickly localizing errors of the crane's sensory system without the need of measuring instruments
- The service starts at the display screen, trouble shooting becomes a matter of seconds
- Occurring errors are indicated by error codes and error descriptions on the display screen
- Convenient interactive functions permit the observation of all in and outputs of the general system by different representations on the monitor, even during crane operation. It also visualizes the allocation of the individual sensors and actuators to the system as well as their function on the display screen

SYSTEM-FUNKTION: AUSSANG		GRUPPE 0
		ZE 0
A 0..n	DOUMENTATION	D I-SOLL I-IST
A 0.0 :	LMB >100%, Ueberbrueckg. - Klingel (D)	1 500 - 520 mA
A 0.1 :	LMB >90%, Vorwahl Klingel (D)	0 0 - 0 mA
A 0.2 :	Pumpe 10 nach TV (D)	0 0 - 20 mA
A 0.3 :	Druckversorgung Hilfsverbraucher (D)	0 0 - 20 mA
A 0.4 :	Drehen Freilauf (D)	0 0 - 0 mA
A 0.5 :	Drehen Bremse (D)	0 0 - 0 mA
A 0.6 :	Drehen rechts (A)	0 0 - 20 mA
A 0.7 :	Drehen links (A)	0 0 - 20 mA

BINHER LEZ/HEX STOP ZURUECK <<=>

The LICCON work area limitation

- It relieves the crane operator, especially in situations where the handling of loads requires his full attention, by controlling the work area limits. Work areas can be restricted by buildings, bridges, roofs, high-tension power lines, pipe lines or adjacent cranes. The automatic work area limitation (optional) can easily be programmed. Four different limitation functions are practicable:
 - Height limitation of the pulley head
 - Radius limitation
 - Slewing angle limitation
 - Limitation of edges

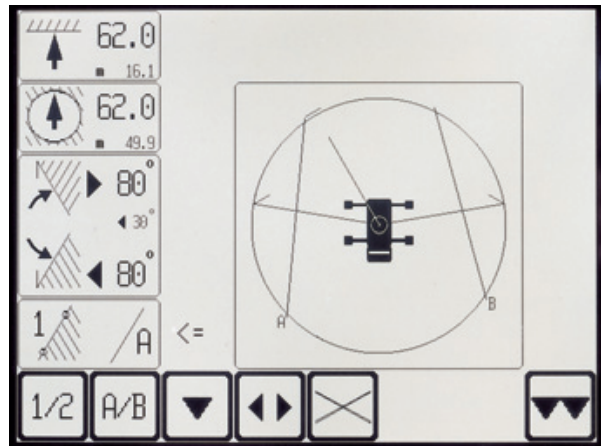

The LICCON work planner

- The LICCON work planner consists of a software program on CD for planning, simulation and documentation of crane applications on the display screen (optional)
- The 2-D planner program permits the drawing of buildings, to write texts and to represent a crane model true to scale including its entire working motions within a fictional construction site
- The work planner enables the preparation of more transparent offers, it facilitates the briefing of the crane operators and can be run on a laptop at the construction site

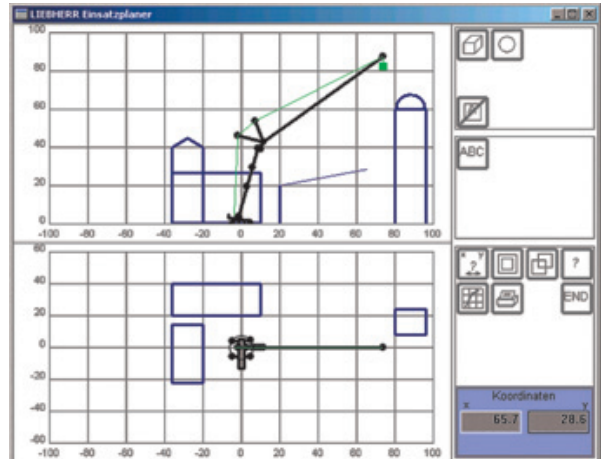

Electric/electronic crane control with integrated safe load indicator

- Control of the winches, the slewing gear as well as the luffing and telescoping motions by the LICCON system (PLC control)
- Four working motions can be performed independent from one another
- Hoisting/lowering and luffing speeds are preselectable by 5 steps
- The luffing speed is controlled automatically in relation to the boom length
- Very short response rates at the activation of crane motions
- Joystick selectors with vibrating motion detectors
- Slewing motion continuously controllable from 0 – 1,5 min⁻¹, additionally 6 steps between 10 % and 100 % preselectable by the LICCON control
- Electrohydraulic interlocking system of the superstructure over front and over rear

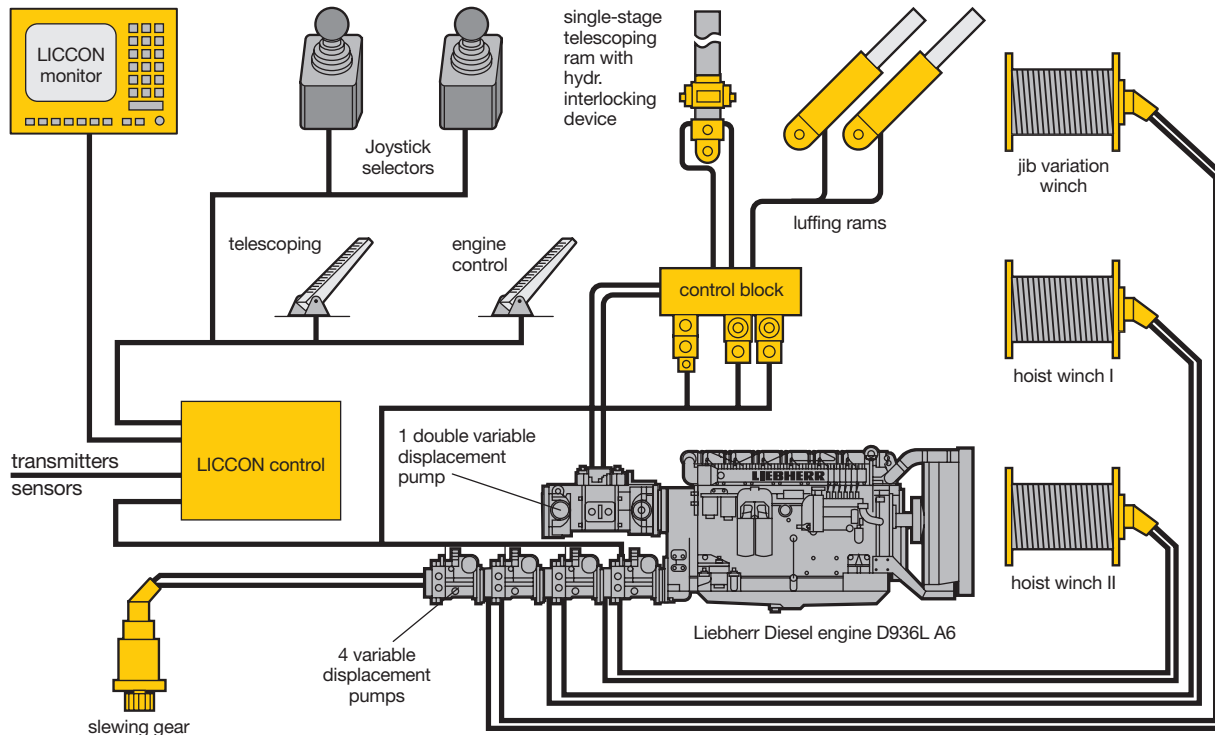

Optional features contribute to an expansion of the application spectrum and increase comfort and safety

On the carrier

- Eddy-current brake
- Outrigger control
- Rope box
- Air-conditioning system
- Radio preparation
- Seat heating for driver's and co-drivers seat
- 3rd seat
- Maneuvering coupling
- Fog lamps
- CD radio set

On the crane superstructure

- Air-conditioning system
- Seat heating
- Video control of the winches
- Work area limitation program
- Working projector Xenon on the telescopic boom base section
- GSM module for tele diagnostic
- CD radio set

Further optional features by request